

UNCLASSIFIED

NAVAIR 00-110AW2-2

GROUP 4 DOCUMENT
DECLASSIFIED AFTER 12 YEARS
DOD DIR 5200.10

Standard Aircraft Characteristics

NAVY MODEL E-2C AIRCRAFT

(TITLE UNCLASSIFIED)

This publication shall not be carried in aircraft on combat missions or when there is a reasonable chance of its falling into the hands of an unfriendly nation, unless specifically authorized by the "Operational Commander."

PUBLISHED BY DIRECTION OF
THE COMMANDER, NAVAL AIR SYSTEMS COMMAND

NOTICE—This document contains information affecting the national defense of the United States within the meaning of the Espionage Laws, Title 18, U. S. C., Sections 793 and 794. The transmission or the revelation of its contents in any manner to an unauthorized person is prohibited by law.

JANUARY 1970

Declassified by NAVMCSYSCOM LTR 9601 SJW ser 366 of 12 JUN 75

UNCLASSIFIED

UNCLASSIFIED

NAVAIR 00-116AW2-2

PRE-FLIGHT

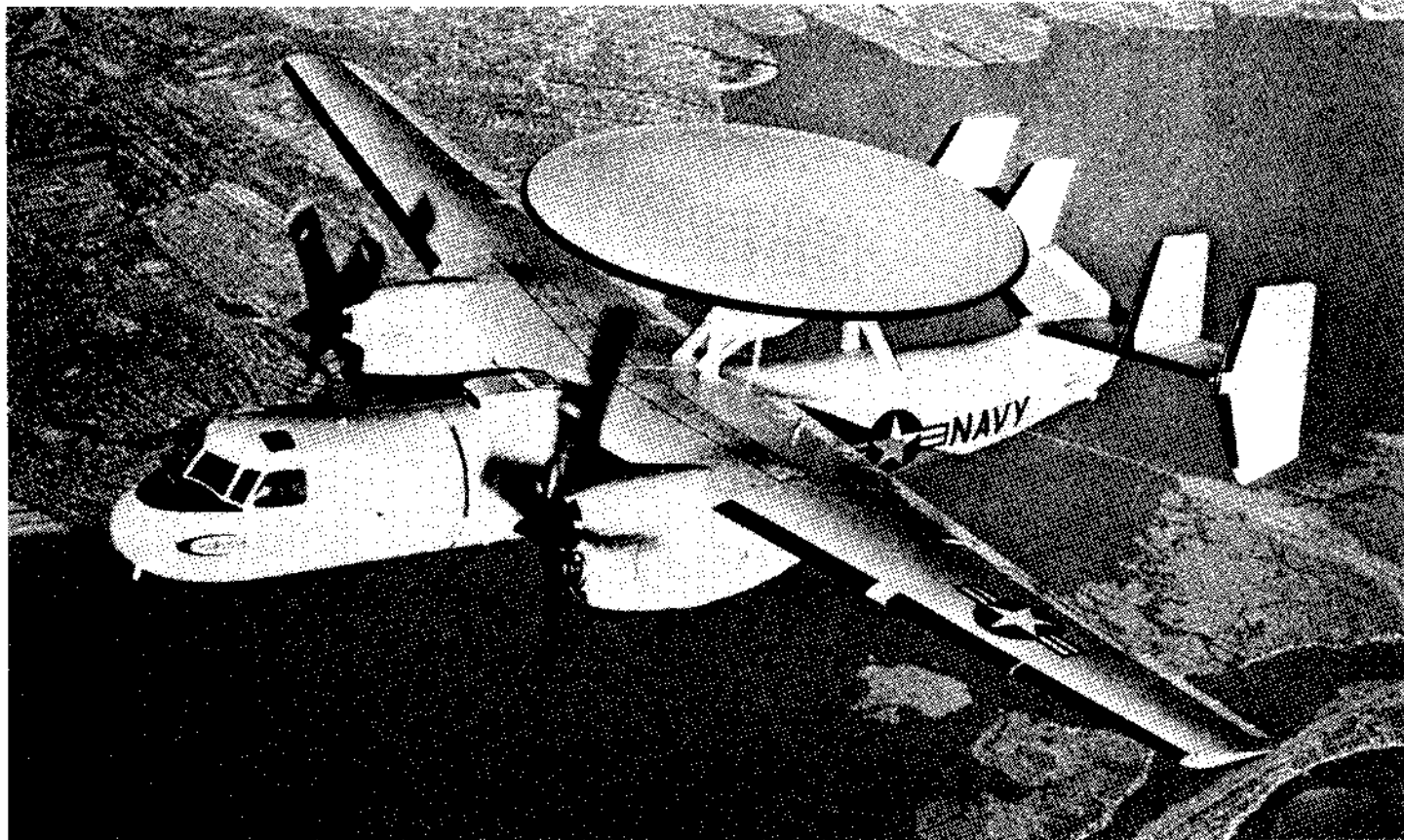

STANDARD AIRCRAFT CHARACTERISTICS

E-2C HAWKEYE

GRUMMAN

~~CONFIDENTIAL~~ 1

E-2C

UNCLASSIFIED

NAVAL AIR SYSTEMS COMMAND
NAVY DEPARTMENT

NAVAL AIR SYSTEMS COMMAND
NAVY DEPARTMENT

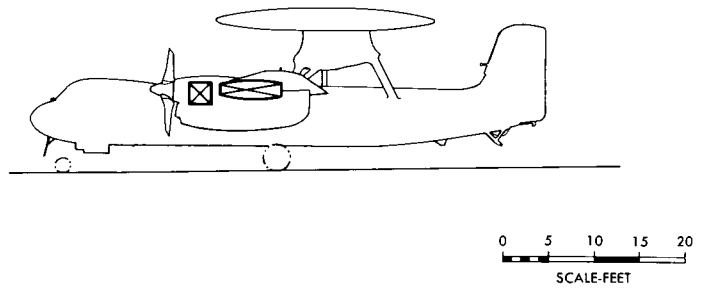
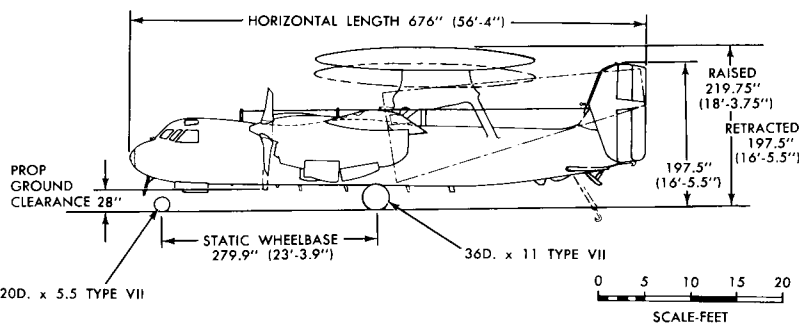
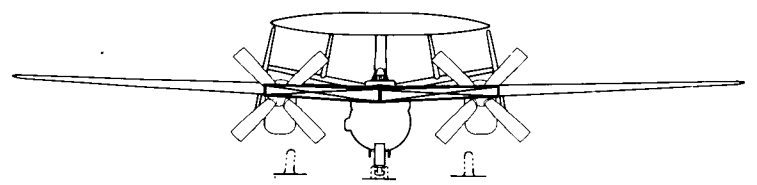
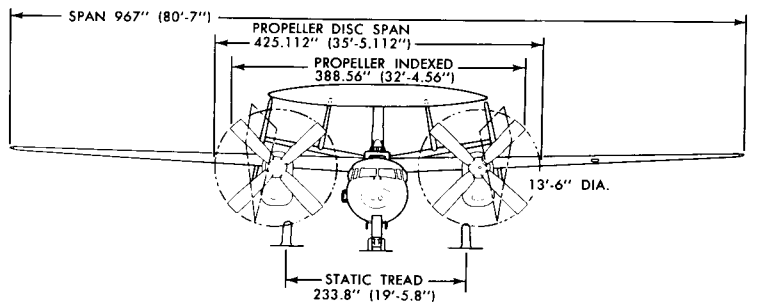
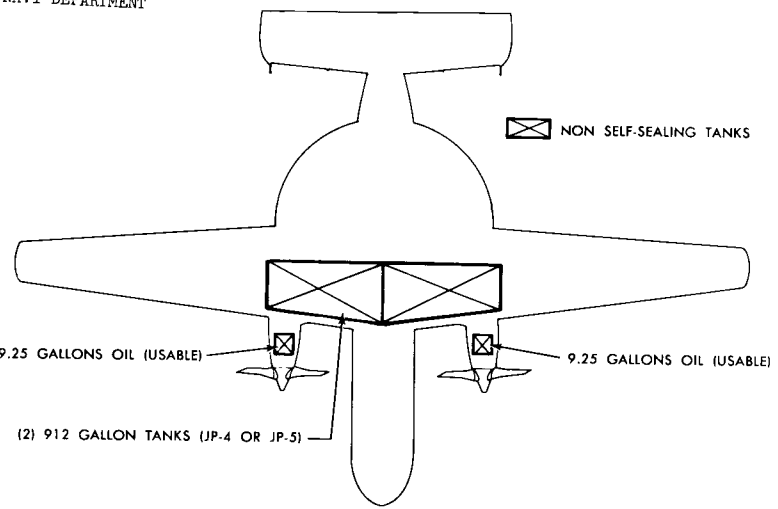
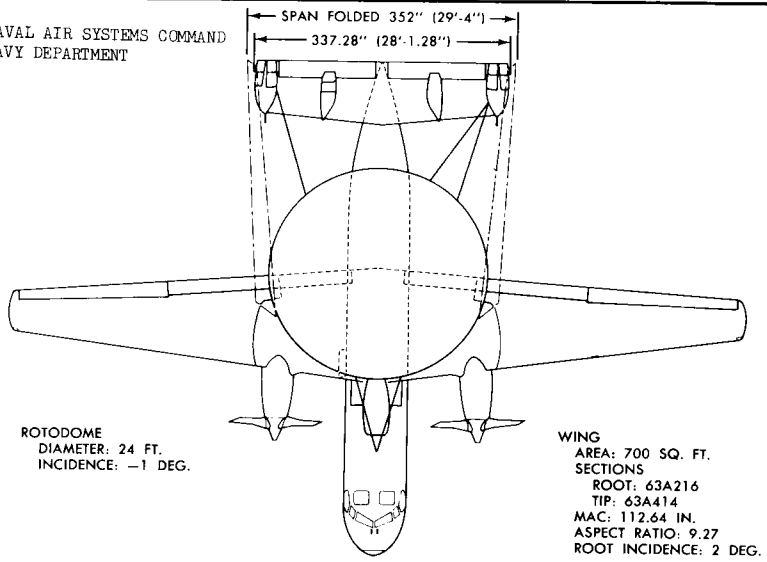

DESCRIPTIVE ARRANGEMENT

ARMAMENT AND TANKAGE

UNCLASSIFIED

NAVAIR CO-110 AW2-2

PRE-FLIGHT

POWER PLANT			
Number & Model	(2)T56-A-8/BA		
Manufacturer	Allison		
Propeller Gear Ratio	12.49:1		
Number of Blades	4		
Propeller Diameter	13 ft. 6 in.		
Propeller Manufacturer	Aero Products		
Propeller Blade Design No.	A6441 FN-248		
RATINGS			
	ESHP	SHP	RPM
Take-Off	4050	3755	13,820
Military	4050	3755	13,820
Normal	3730	3443	13,820
Engine Specification No. 458-E Dated 2 November 1964			

ELECTRONICS	
TACTICAL	
Rotodome	AN/APA- ()
Search Radar Set	AN/APS- ()
IFF Interrogator	RT-868 ()/APX-76
IFF Transponder	KY-533A
Radar Detector Processor	()
IFF Detector Processor	()
Control Indicator Group	AN/APA ()
Computer Programmer	CP- ()
UHF Data Link	AN/ARC-124
Multi-Purpose Communication System	AN/ASQ- ()
Inflight Performance Monitor	AN/ASM-33 ()
COMMUNICATION	
UHF Voice Communications	AN/ARC-51A (PIP)
HF Voice Communications	AN/ARC-104
Intercommunication Set	AN/AIC-14A
NAVIGATION	
Inertial Navigation System	AN/ASN-92 (V) CAINS
Air Data Computer	A/A ()
Doppler Navigation Radar Set	AN/APN-153 (V)
Heading & Attitude Reference System	AN/ASN-50
TACAN	AN/ARN-52
UHF Automatic Direction Finder	AN/ARA-50
Automatic Carrier Landing System (Mode II)	AN/ASW-25A
Radar Altimeter	AN/APN-171 (V)
FLIGHT CONTROL & INSTRUMENTS	
Automatic Flight Control System	AN/ASW-15 ()
Cockpit Altimeters	AAU-19/A

MISSION AND DESCRIPTION	
<p>The Grumman Hawkeye is an all-weather, carrier-based AEW/CIC airplane that patrols task force defense perimeters to provide early warning of approaching enemy aircraft and to vector interceptors into attack position. In addition to this primary AEW function, the Hawkeye can also provide strike and traffic control, area surveillance, search and rescue guidance, navigational assistance, and communications relay.</p> <p>The E-2C features a new generation of avionics and a new equipment cooling system. A suit of avionics that offers both expanded capabilities and improved reliability/maintainability is being developed for packaging in the E-2 Hawkeye airframe using the latest techniques in microelectronics. Also under development is an equipment cooling system of greater capacity and an operational flexibility that will provide improved cooling during pre-launch operations.</p> <p>Designed for a crew of five, the Hawkeye complement is: pilot, co-pilot, radar operator, air-control operator, and combat information center operator. The interior arrangement of the fully pressurized cabin facilitates the interchange of crew positions in an environment which is normally "mask-free". Specialized electronic equipment makes it feasible for three operators to search, identify, and track targets as well as control interceptions. AEW/CIC digital information can be relayed automatically, and an additional UHF communications automatic relay system relieves the crew of "middleman" duty.</p> <p>The automatic flight control system provides crew relief by means of a maneuvering autopilot with both attitude and altitude hold modes as well as TACAN coupling. Precise holding of altitude and turn rate in wings-level turns is provided by the flat-turn mode.</p> <p>Operable from all angle-deck CVA-19 and superior class carriers, the E-2 is catapulted with a nose-tow catapult system. Automatic wing-fold and rotodome lowering permit hangar deck servicing.</p> <p>The Grumman Hawkeye has a high wing and is powered by two T56-A-8/BA turboprop engines. The airplane may be easily identified by the 24-foot diameter rotodome and the four vertical tails. The rotodome, the inboard vertical tails, and the upper portions of the outboard vertical tails are of fiber glass construction. The flight controls are powered by two independent hydraulic systems.</p>	
<p>First Flight (Estimated) _____ March 1971 BIS (Estimated) _____ January 1973</p>	
DEVELOPMENT	
DIMENSIONS	
Wing Span	80 ft. 7 in.
Folded Wing Span	29 ft. 4 in.
Propeller Indexed Span	32 ft. 4.56 in.
Propeller Disc Span	35 ft. 5.112 in.
Length	56 ft. 4 in.
Height (Rotodome raised)	18 ft. 3.75 in.
Height (Rotodome retracted)	16 ft. 5.5 in.
Tread	19 ft. 5.8 in.
Propeller Ground Clearance	28 in.

WEIGHTS			
LOADINGS	LBS.	L.F.	
Empty	37,046 E		
Basic	37,381		
Design	41,996	3	
Combat (60% fuel)	45,960		
Take-off			
Field	50,920		
C-11 Catapult (basic design)	48,390		
Landing			
Field (40% fuel)	43,480		
AK 7 Arresting (3000 lbs. fuel)	41,520		
Weights are based on those presented in the E-2 Aircraft Weapon System Specification, SD-527-2, dated 22 April 1968.			
FUEL AND OIL			
No. of TANKS	GALS. (usable)	LBS. (JP-5)	LOCATION
2 Integral	1824	12,400	C. S. Wing
Fuel Grade _____ JP-4 or JP-5 Fuel Specification _____ MIL-J-5624			
OIL			
Capacity (139 lbs. usable) _____ 9.25 gallons/engine Specification _____ MIL-L-7808			
ORDNANCE			
None			

UNCLASSIFIED

E-2C

PERFORMANCE SUMMARY

TAKE-OFF LOADING CONDITION	①	ON-STATION SEARCH MISSION Service Ceiling (A)	③	ON-STATION SEARCH MISSION 15,000 ft. (A)	⑤	ON-STATION SEARCH MISSION Sea Level (A)	⑦	AREA SEARCH MISSION Cruise Ceiling (A)	⑨	FERRY MISSION (A)
TAKE-OFF WEIGHT lb.		50,920		50,920		50,920		50,920		50,920
Fuel (JP-5) lb.		12,400		12,400		12,400		12,400		12,400
Wing loading lb./sq. ft.		72.7		72.7		72.7		72.7		72.7
Stall speed — power off (zero thrust) kn.		91.5		91.5		91.5		91.5		91.5
Take-off run at S.L. — 59°F day/90°F day ft./ft.		1590/1870		1590/1870		1590/1870		1590/1870		1590/1870
Take-off to clear 50 ft. — 59°F day/90°F day ft./ft.		2285/2660		2285/2660		2285/2660		2285/2660		2285/2660
Maximum speed/altitude (B) kn./ft.		302/10,000		302/10,000		302/10,000		302/10,000		302/10,000
Rate of climb at S.L. (B) fpm.		2515		2515		2515		2515		2515
Time: S.L. to 20,000 ft. (B) (C) min.		13		13		13		13		13
Time: S.L. to service ceiling (B) (C) min.		33.5		33.5		33.5		33.5		33.5
Service ceiling (100 fpm.) (B) ft.		28,800		28,800		28,800		28,800		28,800
Combat radius/mission time n. mi./hr.		200/5.68		200/5.66		200/5.01		200/5.85		—
Station altitude(s) initial/final ft.		22,500/27,600		15,000		Sea Level		24,500/29,500		—
Average cruising speed kn.		268		234		213		268		270
Cruising altitudes initial/final ft.		27,100/33,100		15,000/33,100		Sea Level/33,100		27,100/33,100		27,100/33,100
Time on station/average search speed hr./kn.		4.02/237		3.98/192		3.20/151		4.21/250		—
Range/mission time n. mi./hr.		—		—		—		—		1525/5.78

COMBAT LOADING CONDITION	② 60% FUEL	②A 60% FUEL	④ 60% FUEL	⑥ 60% FUEL	⑧ 60% FUEL	⑩
COMBAT WEIGHT lb.	45,960	45,960	45,960	45,960	45,960	—
Engine power	Normal	Military	Military	Military	Military	—
Fuel (JP-5) lb.	7440	7440	7440	7440	7440	—
Combat speed/combat altitude kn./ft.	289/25,050	304/25,050	315/15,000	307/Sea Level	298/ 27,000	—
Rate of climb/combat altitude fpm/ft.	640/25,050	840/25,050	1825/15,000	3290/Sea Level	650/ 27,000	—
Combat ceiling ft.	26,500	28,600	28,600	28,600	28,600	—
Rate of climb at S.L. fpm.	2930	3290	3290	3290	3290	—
Maximum speed at S.L. kn.	291	306	306	306	306	—
Maximum speed/altitude kn./ft.	305/11,500	315/13,500	315/13,500	315/13,500	315/13,500	—
LANDING WEIGHT lb.	39,756		39,756	39,756	39,756	39,756
Fuel (JP-5) lb.	1235		1235	1235	1235	1235
Stall speed — flight idle/approach power kn./kn.	81/71		81/71	81/71	81/71	81/71
Landing distance — ground roll/over 50 ft. obst. ft./ft.	1250/2230		1250/2230	1250/2230	1250/2230	1250/2230

NOTES

PERFORMANCE BASIS: Calculated data based on flight test results from the performance demonstration of the E-2A airplane, adjusted for estimated E-2C drag increments, and calibrated engine data with no increase in fuel consumption.

(A) See Mission Profiles page.

(B) Normal power.

(C) Take-off gross weight minus fuel for warm-up, taxi, take-off, and climb.

SPOTTING: A total of 47 airplanes can be accommodated on the flight and hangar decks of a CVA-19 class angled deck carrier.

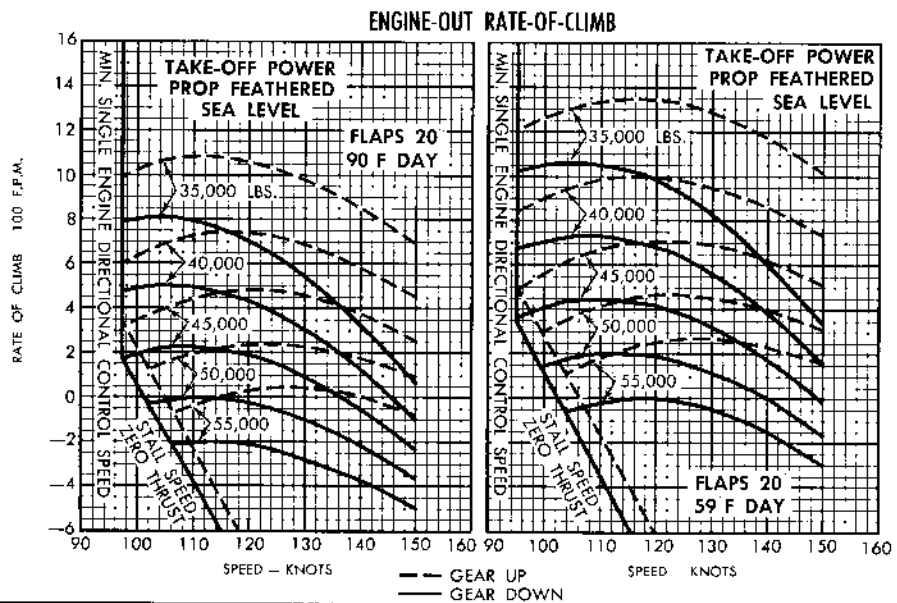
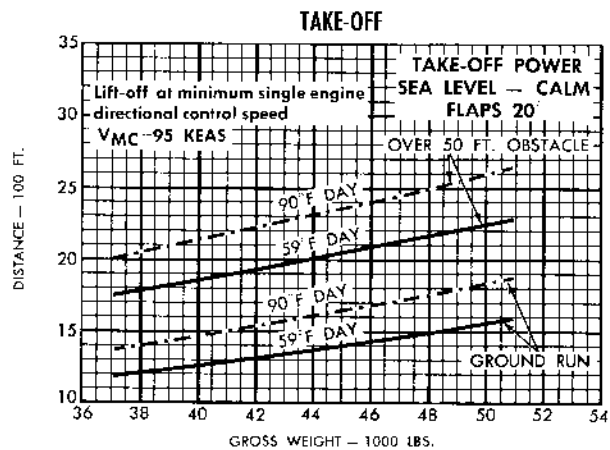
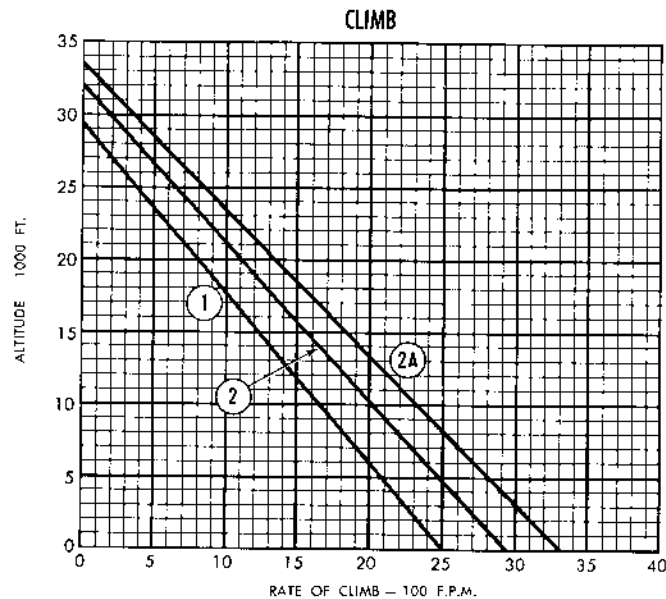
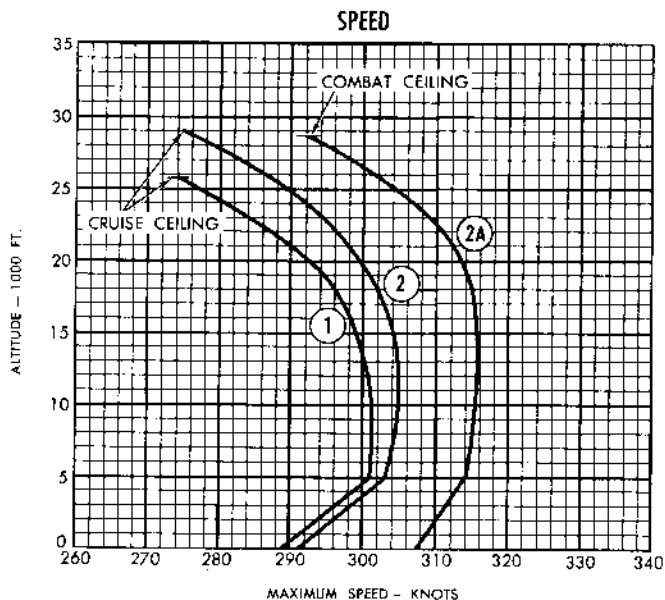

○ LOADING CONDITION COLUMN NUMBER

MISSION PROFILES

ON-STATION SEARCH MISSION

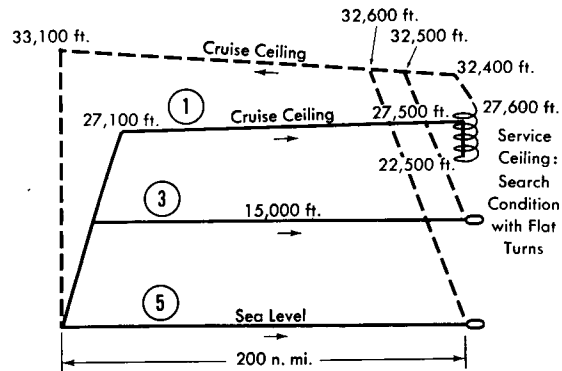

Warm-up, taxi, take-off: 5 minutes with normal power at sea level.

Climb on course to cruise-out altitude with normal power.

Cruise at speed for maximum range at cruise-out altitude to total distance of 200 nautical miles from base.

On-station in search condition (10° flaps, at speed for 3° radar attitude) at station altitude. Hold on station in a 50 nautical mile race track pattern using 0.6 degrees per second flat turns.

Climb back to best cruise altitude with normal power.

Cruise at speed for maximum range at best cruise altitude to base.

Fuel allowance for reserve is 5 per cent of initial fuel and fuel required for twenty minutes at speed for maximum endurance at sea level.

AREA SEARCH MISSION

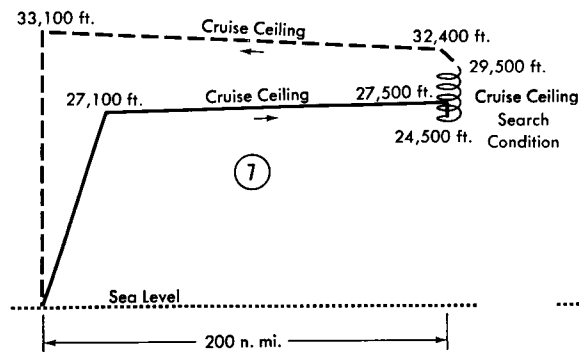

Warm-up, taxi, take-off: 5 minutes with normal power at sea level.

Climb on course to best cruise altitude with normal power.

Cruise at speed for maximum range at best cruise altitude to total distance of 200 nautical miles from base.

Area surveillance in search condition (10° flaps, at speed for 3° radar attitude) at cruise ceiling. No flat turning.

Climb back to best cruise altitude with normal power.

Cruise at speed for maximum range at best cruise altitude to base.

Fuel allowance for reserve is 5 per cent of initial fuel and fuel required for twenty minutes at speed for maximum endurance at sea level.

FERRY MISSION

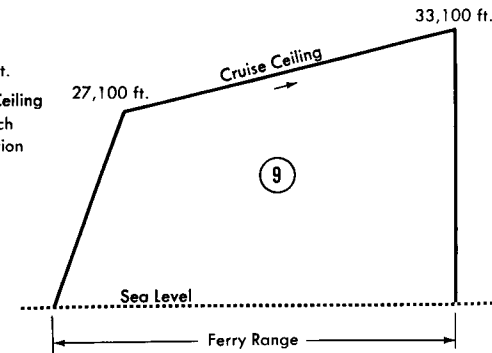

Warm-up, taxi, take-off: 5 minutes with normal power at sea level.

Climb on course to best cruise altitude with normal power.

Cruise at speed for maximum range at best cruise altitude

Fuel allowance for reserve is 5 per cent of initial fuel and fuel required for twenty minutes at speed for maximum endurance at sea level.

○ LOADING CONDITION COLUMN NUMBER

SEARCH TIME ON STATION

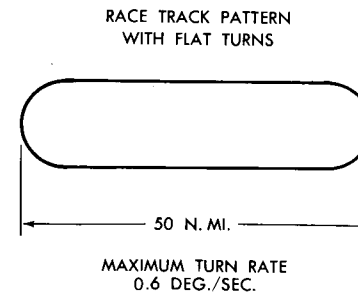
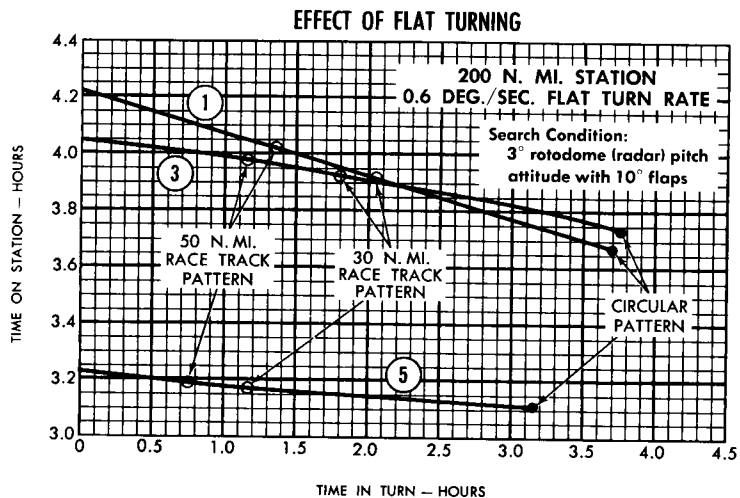
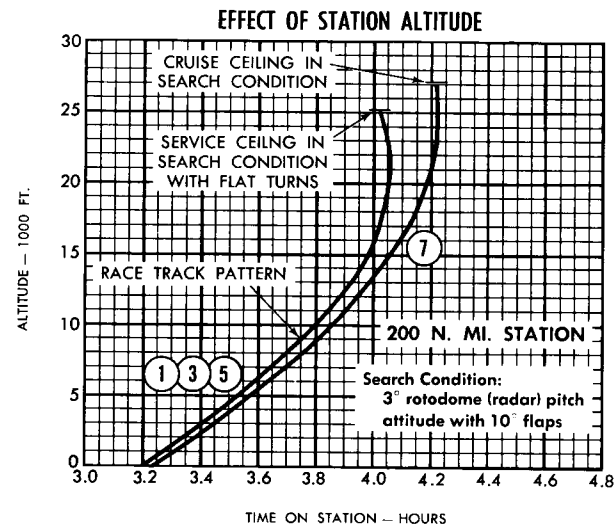
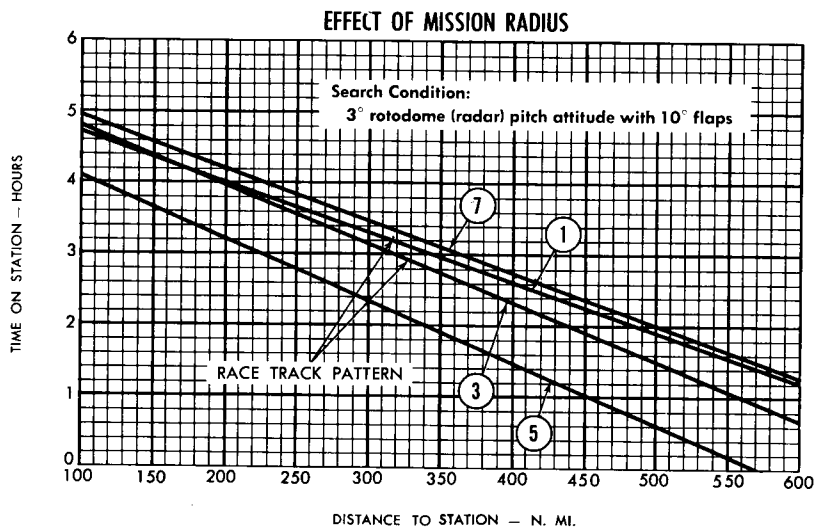

○ LOADING CONDITION COLUMN NUMBER

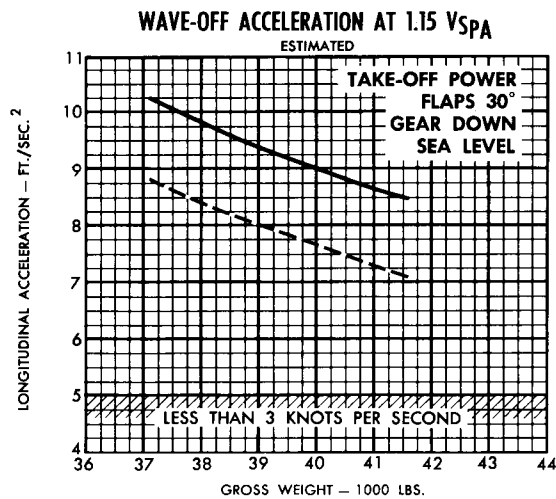
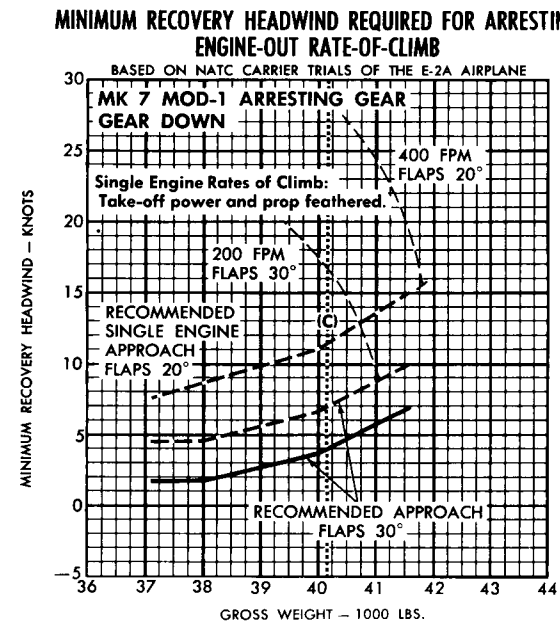
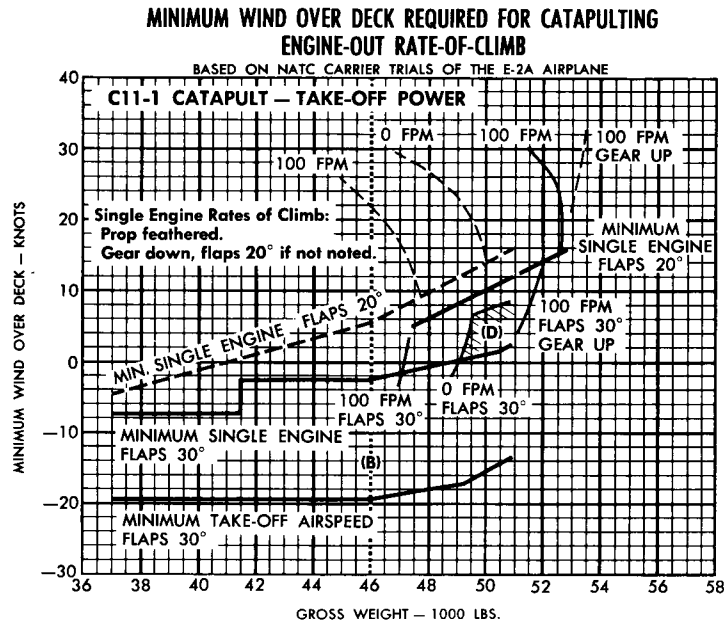

--- TROPICAL (90°F) DAY
 — STANDARD (59°F) DAY

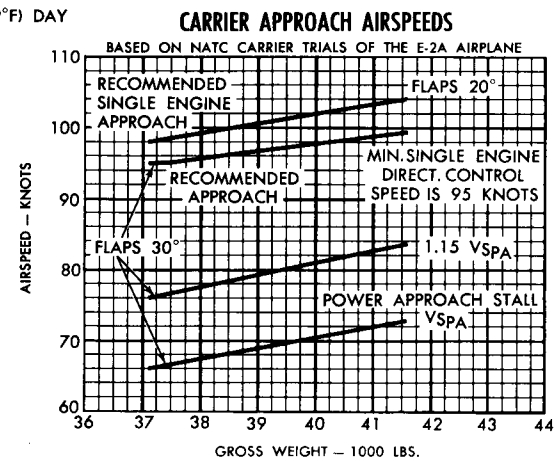

(C) MK 7 Mod-1 Arresting Gear with sheave dampers, 95 ft. span. Maximum engaging speeds are limited by aircraft cg drag acceleration limit below 40,200 pounds and by aircraft hook strength above 40,200 pounds.
 (D) Single engine flight in this region incurs sink rates with full power while on the back side of the speed-power required curve.

(A) These data are for planning only. Carrier air operations are prescribed by Aircraft Launching Bulletins, Aircraft Recovery Bulletins, NATOPS Flight Manual, and CVA CVS NATOPS Manual.
 (B) C11-1 Catapult. Maximum endspeeds are limited by aircraft cg drag acceleration limit below 46,000 pounds and nose tow link load limit above 46,000 pounds.